

SECTION B-B

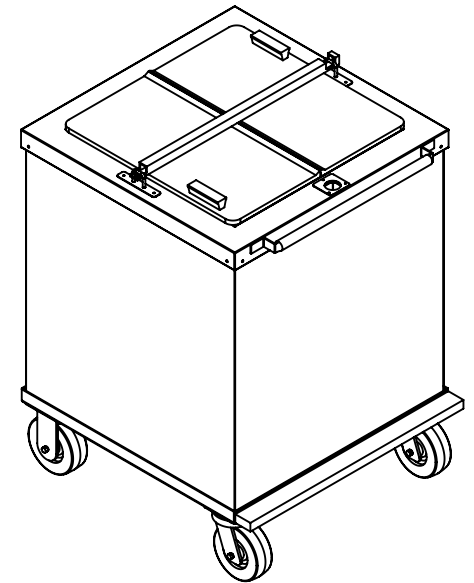

UNLESS OTHERWISE SPECIFIED: DIMENSIONS ARE IN INCHES TOLERANCES: FRACTIONAL ± ANGULAR: MACH ± BEND ± TWO PLACE DECIMAL ± THREE PLACE DECIMAL ±	DRAWN PAC	NAME PAC	DATE 1/12/2012	C. Nelson Mfg. TITLE: CLT-4NR
	CHECKED			
	ENG APPR.			
	MFG APPR.			
PROPRIETARY AND CONFIDENTIAL THE INFORMATION CONTAINED IN THIS DRAWING IS THE SOLE PROPERTY OF C. NELSON MFG. ANY REPRODUCTION IN PART OR AS A WHOLE WITHOUT THE WRITTEN PERMISSION OF C. NELSON MFG. IS PROHIBITED. DO NOT SCALE DRAWING	Q.A.			SIZE A
	COMMENTS:			DWG. NO. 331
				REV
		SCALE: 1:16	WEIGHT:	SHEET 1 OF 1