

www.cnelson.com .sales@cnelson.com
 265 N. Lake Winds Parkway
 Oak Harbor, OH 43449, U.S.A.
 Anytime, Anywhere

NELSON Flavor Rail Cabinets

Call Sales 419-898-3305
 For more information

Perfect preservation of product quality and flavor...continuous failure-free operation that virtually eliminates maintenance...absolute minimum of operating costs...these are the advantages offered by Nelson's superior design and construction which can only be measured over long periods in terms of service and value. Since 1898, the industry's finest equipment for the protection of quality and flavor in ice cream and frozen foods. Now, with the lowest prices on the internet , see Nelson for the best deals on ice cream dipping equipment. For a serious Ice Cream Business, experienced or start-up, you need a Nelson Dipping Cabinet

FEATURES:

- * INTEGRAL JAR RACK KEEPS CONTENT OF JARS CHILLED
- * DIGITAL THERMOSTAT
- * IN & OUT AIRFLOW THROUGH OPERATOR SIDE
- * PERMANENT STAINLESS STEEL GASKETS



SPECIFICATIONS:One piece 22 ga. 304 stainless steel, all corners welded (no corner pieces or raw edges, ever), Galvanized steel reinforced sub-top beneath the stainless top, Anti-condensate heater wires on galvanized sub-top to prevent condensation on cabinet top, 24 ga stainless steel interior. Optional 22 ga. 304 stainless steel exterior , Copper tubing cold wall type evaporator attached to liner wall, Forced air condensing unit (clog free design on all BD models) on glide-out base for efficient operation and built-in applications, Base of cabinet to be constructed of 16 ga. Galvanized steel, Poured-in place urethane foam insulation with a minimum "K" factor of .13, Lids to be stainless steel top with poured urethane foam insulation and hinged in the center with rubber handles, Cabinet to be equipped with a 7-ft power cord, 3 wire, grounded, dead front construction, Unit NSF & ETL approved.

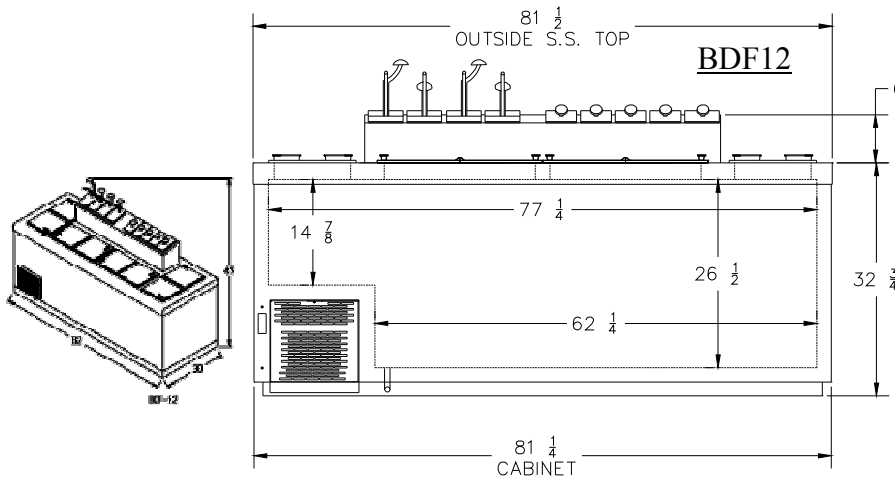
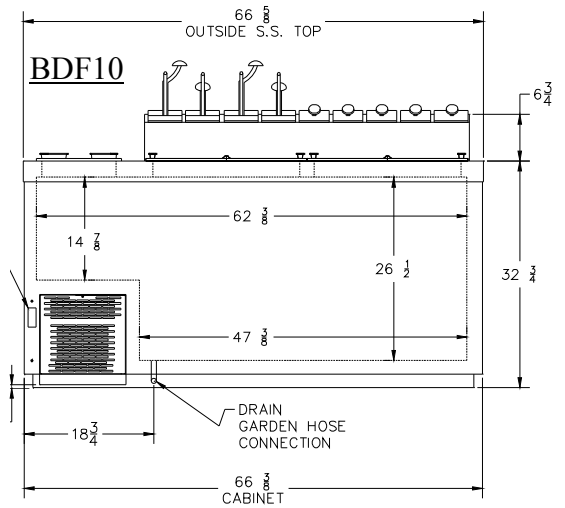
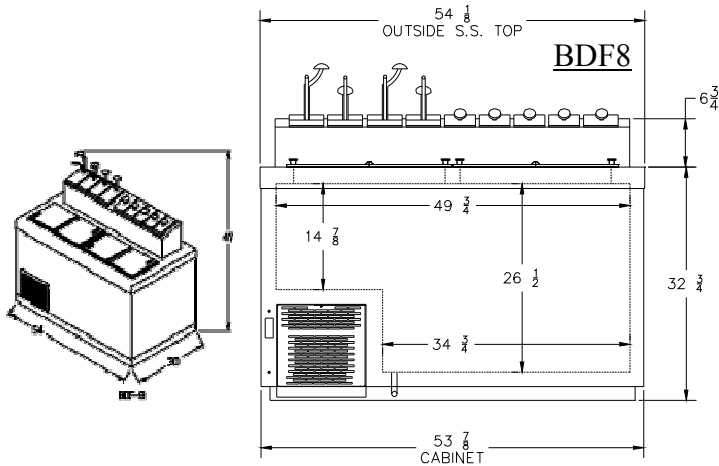
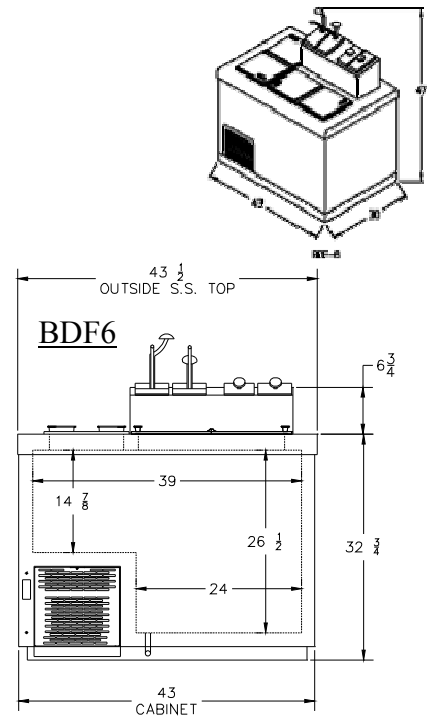
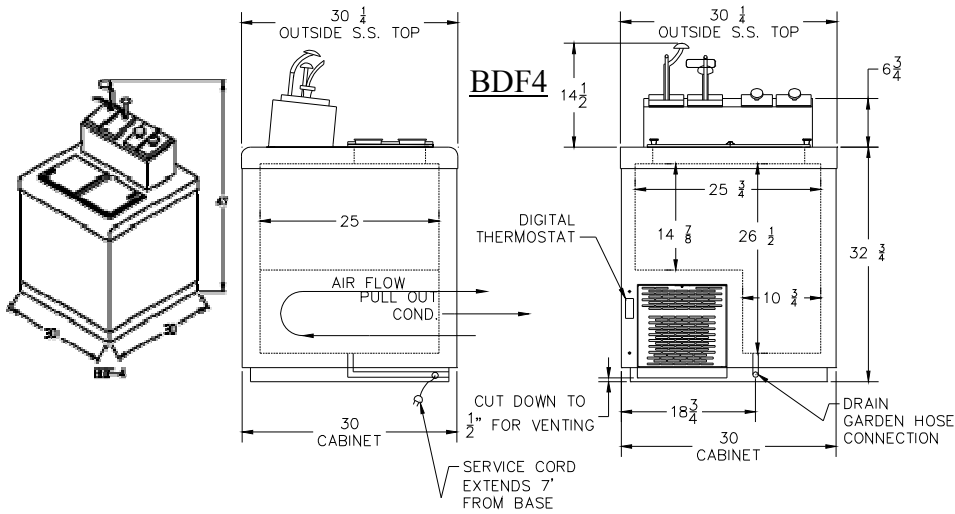

Specifications	BDF4	BDF6	BDF8	BDF10	BDF12
SHIP WT.	260	325	345	370	430
CuFt FREEZER	7.5	13	17.5	23	28
TOTAL TUBS	7	13	19	25	33
CU FT REFRIG	N/A	N/A	N/A	N/A	N/A
COMPRESSOR	1/3 HP	1/3 HP	1/3 HP	1/3 HP	1/2 HP
AMPS	8	8	8	8	11
ELECTRIC	115 v.	115v.	115v	115v	115v

Optional Pump, Jar & Ladle Kits available

Flavor Rail Cabinets are Available in white enamel finish, stainless exterior or stainless steel interior & exterior