



www.cnelson.com sales@cnelson.com  
265 N. Lake Winds Parkway  
Oak Harbor, OH 43449, U.S.A.  
Anytime, Anywhere  
419-898-3305

# NELSON Self-Contained Sinks

Wash away your Local Health Department concerns. Nelson sinks can be used as stand-alone carts or made integral with any other Nelson Mobile carts.



419-898-3305



www.enelson.com sales@enelson.com  
 265 N. Lake Winds Parkway  
 Oak Harbor, OH 43449, U.S.A.  
 Anytime, Anywhere

# Self-Contained Hand Wash Sink

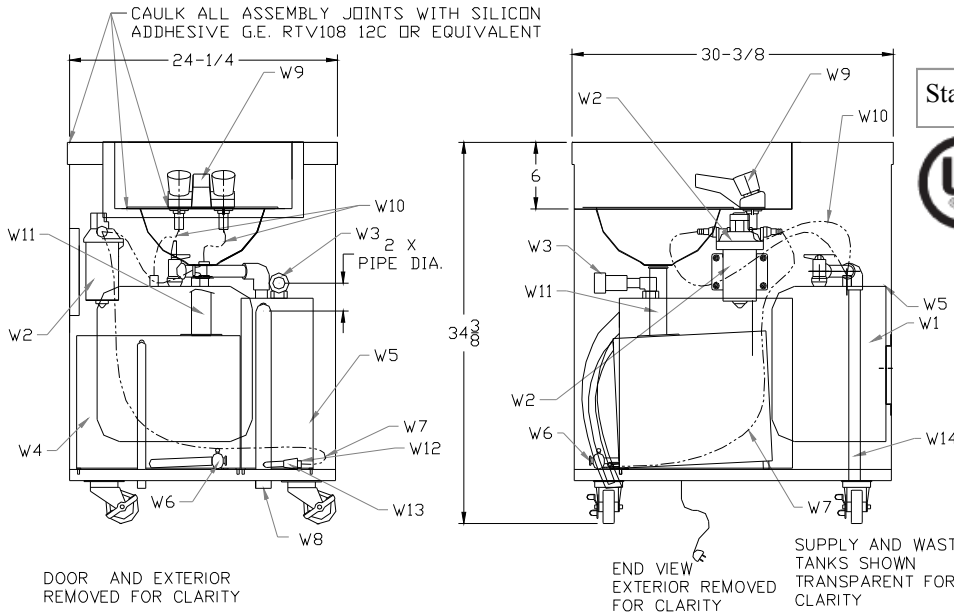

DRAIN TO WASTE TANK IS REMOVABLE WITHOUT TOOLS. ALLOWING TANK TO BE REMOVED WITHOUT TOOLS. THIS ALLOWS THE FRESH WATER TANK TO BE PULLED FORWARD DISCONNECTED AND REMOVED WITHOUT TOOLS.

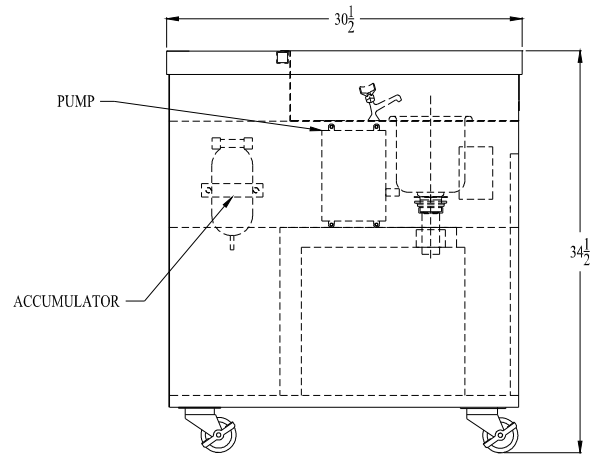
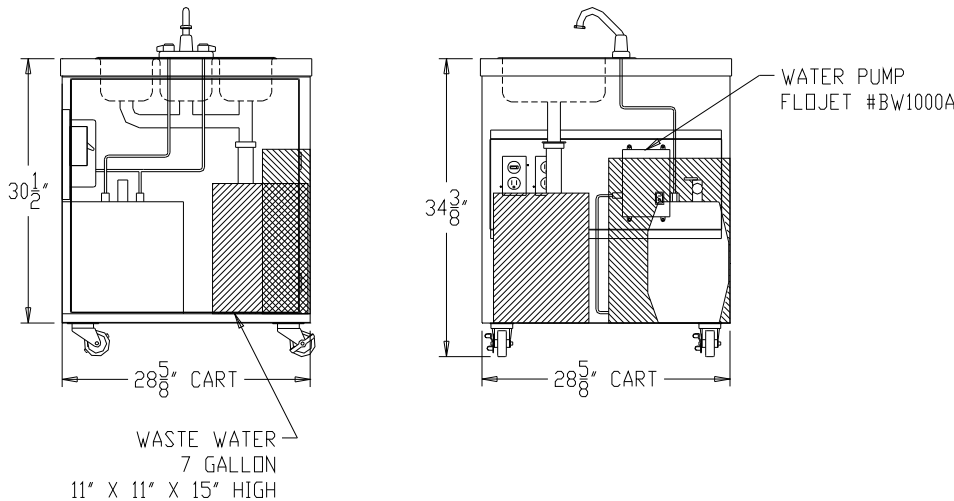
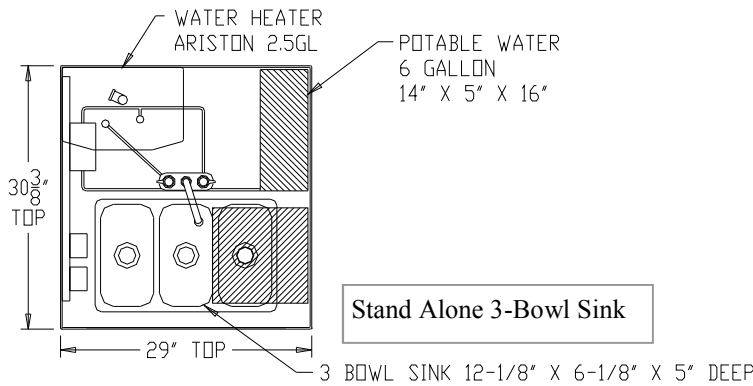

419-898-3305



www.cnelson.com sales@cnelson.com  
 265 N. Lake Winds Parkway  
 Oak Harbor, OH 43449, U.S.A.  
 Anytime, Anywhere

ITEM #	QTY	P/N	DESCRIPTION	MANUFACTURER	MFG MODEL	LISTINGS
W1	1	YZ2075	WATER HEATER	ARISTON	GL2.5	UL
W2	1	YS0010	WATER PUMP	SHURflo	8025-733-256	UL,NSF
W3	1	YZ2037	QUICK CONNECT	HANSON	4HK	NSF
W4	1		(9) GALLON WASTE WATER TANK STAINLESS STEEL	C.NELSON MFG	12743TUBE	
W5	1		(5.9) GALLON FRESH WATER TANK STAINLESS STEEL	C.NELSON MFG	12742TUBE	
W6	1	YP0260	SHUT OFF VALVE	McMASTER CARR	4876K41	NSF
W7	**	YZ2033	PUMP SUPPLY TUBING 3/8" ID	KURITEC	K3150-06X50	NSF
W8	**	YZ2083	WASTE TANK OVERFLOW/FAUCET SUPPLY 1/2" ID	KURITEC	K3150-08X50	NSF
W9	1	YZ0356	FAUCET	UTOPIA	20377207	UPC
W10	2	YZ0363	ACCUMULATOR, FAUCEL CONNECTION LINES	SPEEDI PLUMB PLUS	PSB84S	CSA, UL, UPC
W11	1	YZ0365	TAILPIECE	CAMCO RV	37311	
1	2	YZ2004	OUTDOOR DUPLEX BOX	HUBBLE	5958-0	UL,CSA
2	1	YE02341	DUPLEX RECEPTACLE GFI TYPE	LEVITON	7899-A	UL,CSA
3	1	YE02340	SWITCH/RECEPTACLE	LEVITON	5320-ICP	UL,CSA
4	1	YE0210	JUMPER CORD	14 GA WIRE		UL
5	1	YZ1015	FLEXIBLE CONDUIT	SUPERFLEX LTD	8451	UL,CSA
6	1	YE0113	SOW 12/3 CORD WITH MOLDED PLUG	MID-STATE MFG CORP	CNM-AP36-180SO	UL,CSA
7	7		304 SS CONSTRUCTION	C. NELSON MFG		
8	4	YC0110	3" SWIVEL CASTERS W/BRAKE	JARVIS PEMCO	75832	

**SPECIFICATIONS:**

- Constructed of 18 and 22 gauge type 304 stainless steel.
- Requires 120/1/60 electrical outlet 15 amp circuit.
- Sink bowl 21 gauge S.S. 11.5" Diameter x 5 1/4" deep.
- Chrome 4" lavatory faucet with crystal handles.
- Sink drain (1.5" Dia.) with strainer & stopper.
- Ariston water heater Model GL2.5, 2.5 gal. capacity 110/1/60 12.5 fl a., 1500 watt/12 amps. (UL, CSA compliant).
- Shurflo series 8000 diaphragm pump, 115/1/60, .61 fl a., 1.7 gpm free flow, w/pressure shutoff, .5 amp (NSF, UL). Optional Flojet pump 120/1/60, .5 fl a, .8 gpm., .6 amps (NSF).
- Supply tank with fill port & overflow-6 gal. nominal capacity.
- Waste tank with overflow & drain-9 gal. nominal capacity.
- Castors - 4" swivel with brake.
- Optional quick coupling fill valve.

419-898-3305



www.cnelson.com sales@cnelson.com  
265 N. Lake Winds Parkway  
Oak Harbor, OH 43449, U.S.A.  
Anytime, Anywhere

Nelson sink systems are manufactured as stand alone units or can be integrated into any of our Mobile dipping carts models. The Carts, whether for dipping Ice Cream, Gelato or Italian Ice can include a dipper well, hand wash sink, triple bowl utensil washing sink, or any combination of the above. The components used in any case are listed on page 2 of this document.. A portable gravity fed dipper well system is also available for venues without a power source. It is the buyers responsibility to ensure all local health codes are met when ordering your equipment.

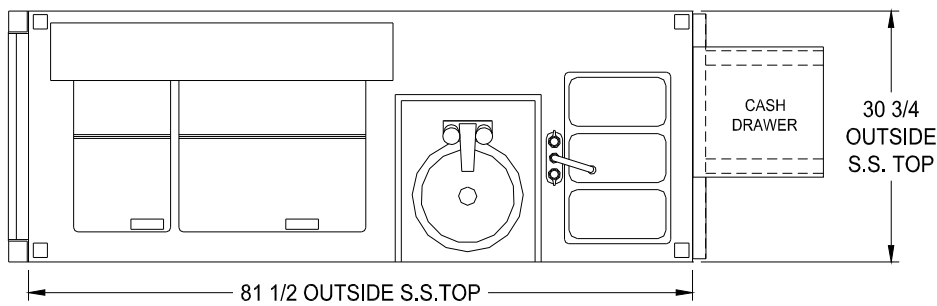

Model BD6CE-07 Cart  
With integral sinks  
Shown with optional cash drawer

